

Amplifier A.D. Audio model « SFORZANDO », made in Belgium

Drawn by Thierry Magis, 2008 -- <http://www.radiocollection.be> --

Free to use file and documentation, CANNOT BE SALE.

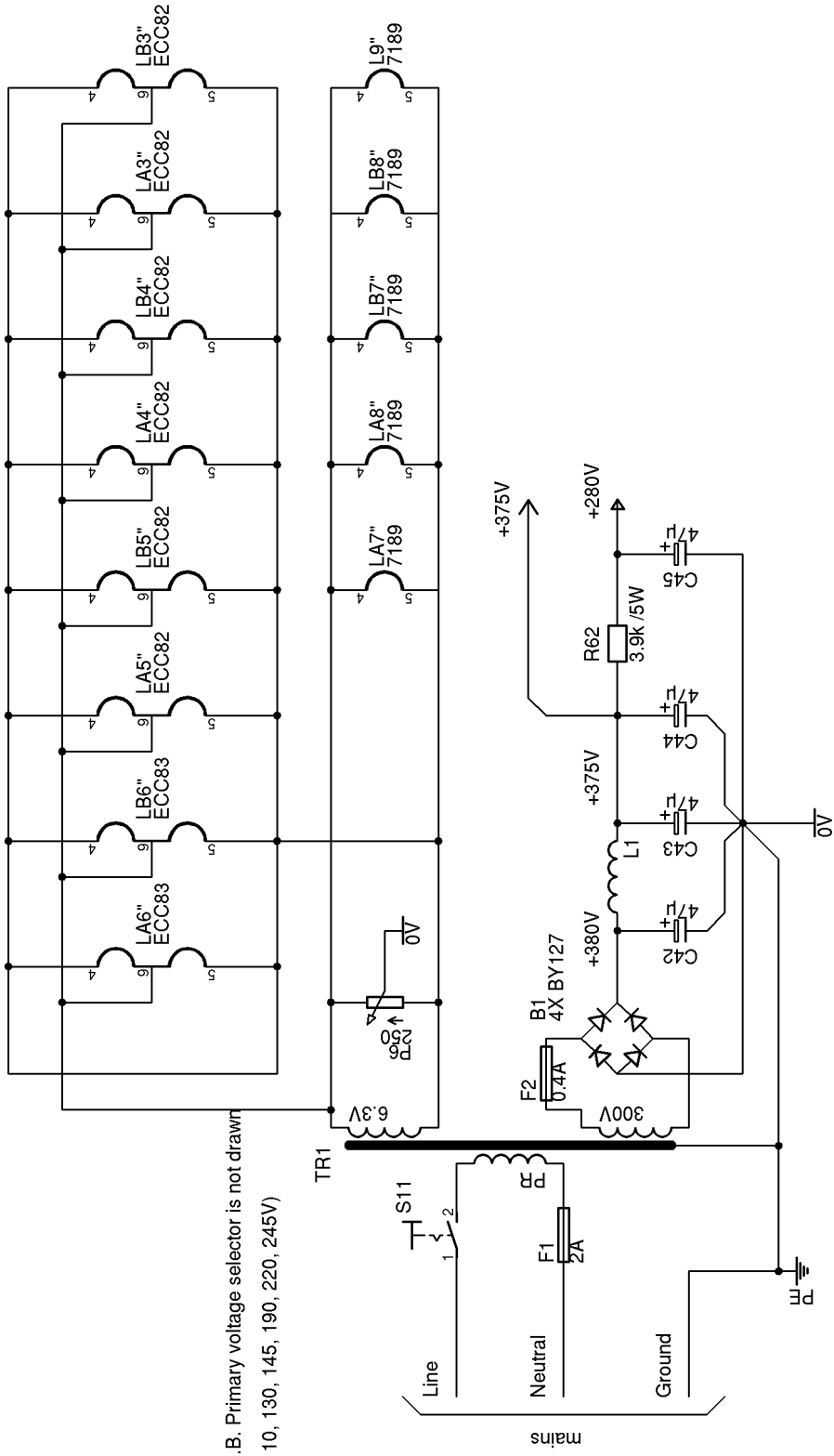

N.B. Primary voltage selector is not drawn
(110, 130, 145, 190, 220, 245V)

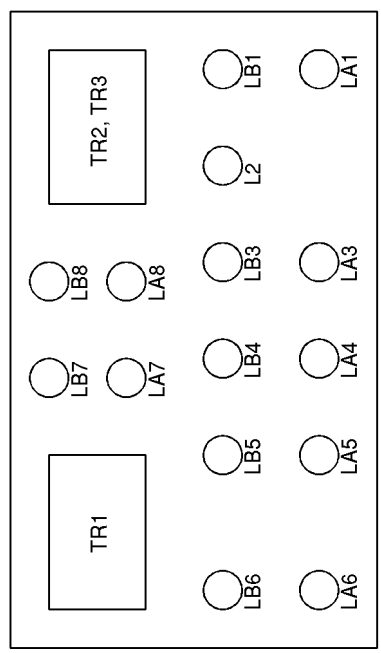

Tube position (component side)
L9 is the expander indicator
(near expander potmeter)

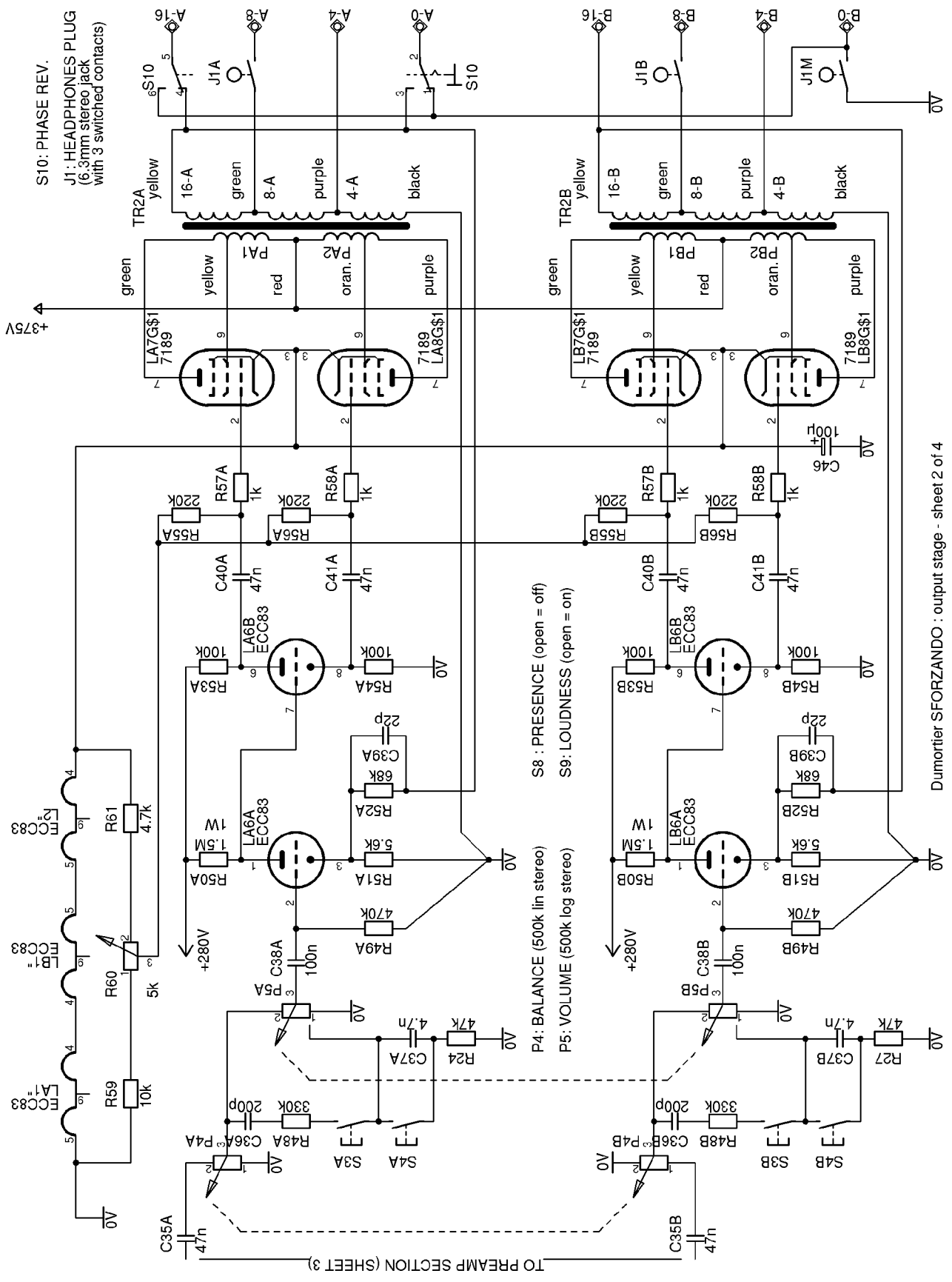

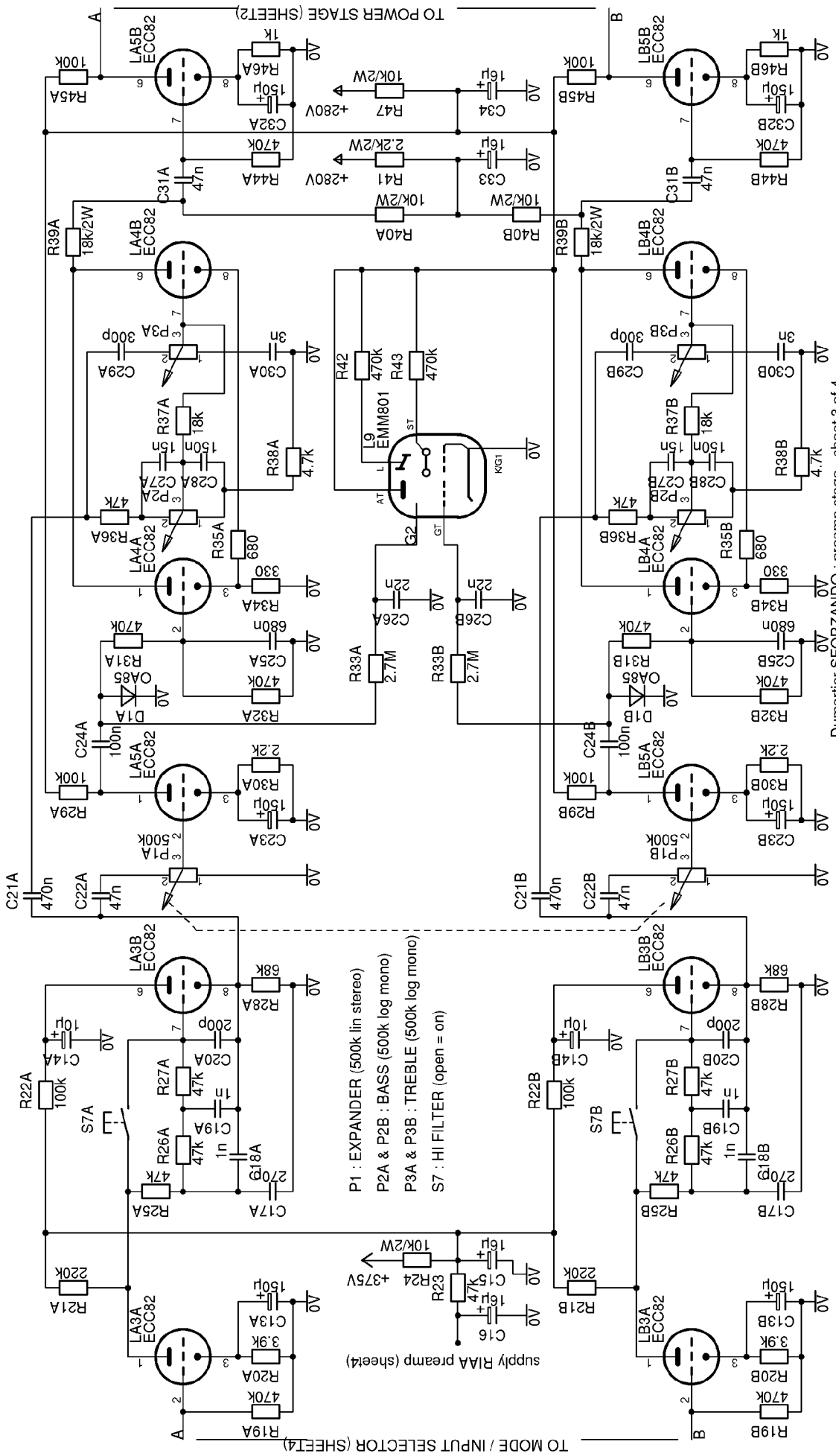

Dumortier SFORZANDO : preamp stage - sheet 3 of 4

